



**SHARMIC ENGINEERING LIMITED**  
SURFACE FINISHING EQUIPMENT & CONSUMABLES

# VP/HA AUTOMATIC VIBRATING WASHING SYSTEM

Revolutionary multipurpose vibrating machine, able to perform:

- Degreasing
- Deburring
- Descaling
- Pickling
- Polishing
- Soaping
- Drying with hot air suction

	Capacity dm <sup>3</sup>	Dimensions			Motor KW	Heating KW
		A	B	C		
VP/HA 10	10	490	800	120	0,35	3
VP/HA 40	38	670	800	160	0,55	6
VP/HA 60	60	930	900	225	0,73	12
VP/HA 150	150	1140	1000	270	1,5	18
VP/HA 270	270	1380	1100	320	2,5	18
VP/HA 380	380	1560	1250	360	3,5	24



## CASES

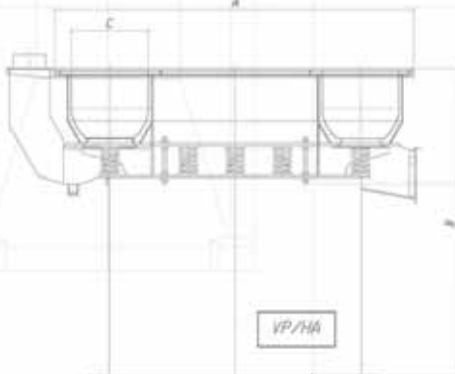

In a single unit all processes can be performed without risk of component contamination or damage.

Capacity from 10 up to 400 dm<sup>3</sup> / hour.

With VP/HA system, drying is achieved by suctioning hot air through the components in vibration: this system perfectly dries even the most complex components without stains or dust.

Drying process temperature is automatically controlled by our revolutionary PID system which uses 30% less time and power.



**SHARMIC ENGINEERING LIMITED**  
SURFACE FINISHING EQUIPMENT & CONSUMABLES

## VP/HA FULLY AUTOMATIC SYSTEMS, complete with:

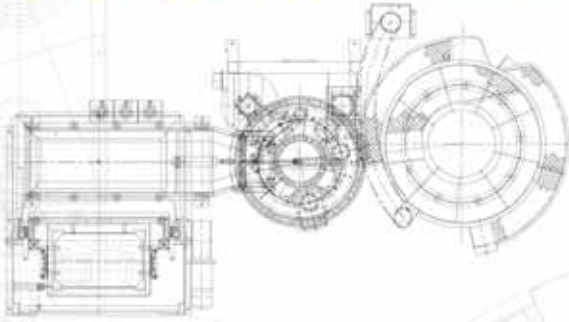

- PLC controls
- Loading system
- Water & chemicals dosing systems
- Chemicals recycling systems
- Soundproofing
- Integrated hot air and maize drying

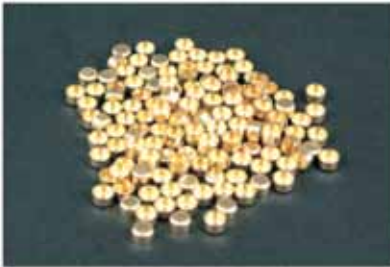

**CAPSULES**



**CUPS**



**SLEEVES**



Registered Office: Baldwin Road, Stourport-on-Severn, Worcs. DY13 9AX

📞 +44 (0)1299 822135 📠 +44 (0)1299 878123/4/5 📠 +44 (0)1299 879409

✉️ [info@sharmic.co.uk](mailto:info@sharmic.co.uk) 🌐 [www.sharmic.co.uk](http://www.sharmic.co.uk)